

Structural Analyses For a Space-Flight

Adam Dacko^{1,2, a)}, Tomasz Kowalski², Jędrzej Baran² and Tomasz Barciński²

¹Faculty of Power and Aeronautical Engineering, Warsaw University of Technology, Poland.

²Space Research Centre, Polish Academy of Sciences, Warsaw, Poland

^{a)}Corresponding author: adam.dacko@meil.pw.edu.pl

Abstract. Since couple of years, Space Research Center of Polish Academy of Sciences (CBK PAN) is increasingly involved in current projects of European Space Agency. Involvement results in successful innovative designs, some of which are finally located in the space, fulfilling the missions in the deep space. CBK recent projects include structural analyses verifying the design. The paper presents some aspects of mechanical analyses (excluding here the thermal loads) of the equipment for Jupiter Icy Moons Explorer (JUICE) – the ESA mission with the launch date set to 2022.

INTRODUCTION

Structural verification of the space exploration equipment is performed by Finite Element analysis of thermo-mechanical response of the mechanical assembly of electronic parts. E.g. Fig. 1 (a) shows the “EBOX” assembly, consisting of set of PCBs, set in frames (b) ensuring a proper mechanical stiffness. The thermal aspect of the load and response is not discussed here. The analyses are mainly dynamic, with quasi-static overload 70g as an exception.

FINITE ELEMENT MODELING

Some of the components (see Fig.1, EBOX) are modeled using mainly thin-shell approach, with small contents of solid or other elements. Other parts are more “bulky”, (see Fig.2, PreBOX) – resulting in a solid-mainly FE model.

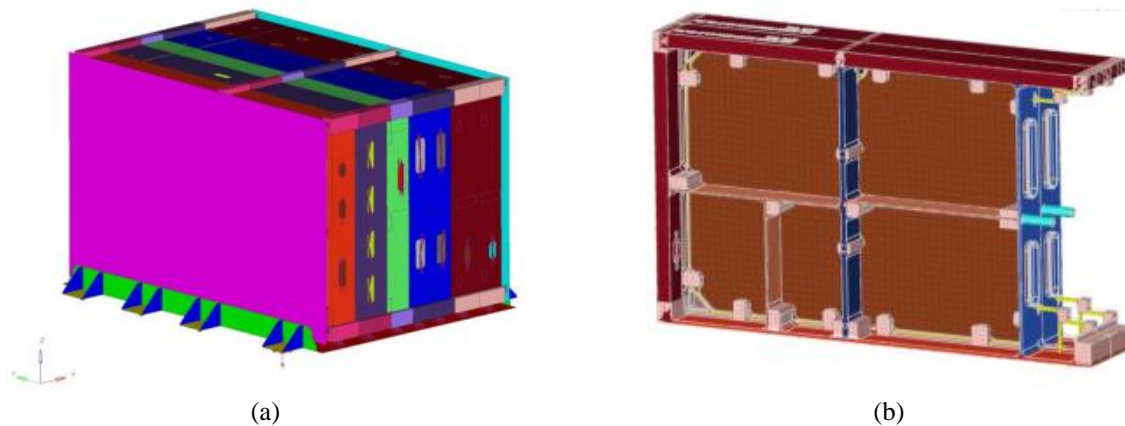

FIGURE 1. EBOX - assembly (a) of electronic Printed Circuit Boards (PCBs) . In (b) a double-frame PCB is “extracted” as an illustration of the assembly component. The back face of PCB is visible, not showing IC elements, but showing stiffening ribs.

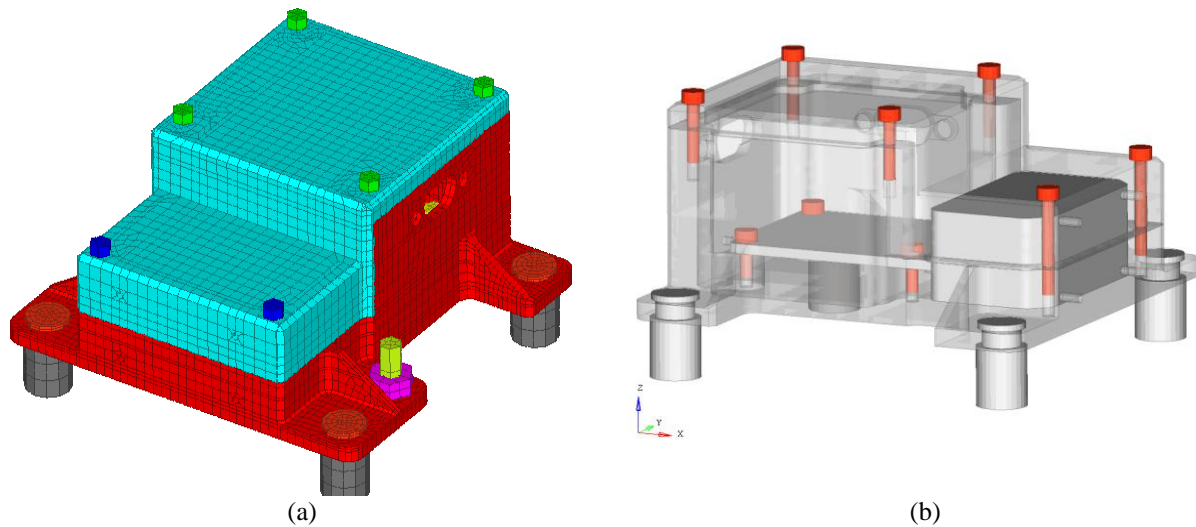

Figure2. PreBOX- the aluminum casing (a) is mounted directly to the spacecraft, and contains a flat PCB inside. A smaller box inside the Alu casing - visible in (b) - is an internal tantalum box, shielding some IC components of the PCB against radiation.

STRUCTURAL ANALYSES

The basic elements of FE model are obvious – SHELL elements or SOLID elements are used, depending on the “slenderness” of the components. Other special elements are also used. The most common are CBUSH elements, modelling flexible connections. For distributing connections and loads, RBE2 elements (stiff connection) or RBE3 (load distribution) are used. The bolts and preloads are modelled including “standard FE“ bolt-tensioning tools. This solutions lead to “pre-stiffened” nonlinear analyses. This approach, along with contact occurring in assemblies creates nonlinear FE problems disabling direct modal analyses. And one of the absolutely BASIC aerospace requirements is keeping the first eigenvalue above some modal threshold – value of which depends on the launching rocket type.

The advanced dynamic analyses include Frequency Response (Harmonic) and Transient Response. Both have direct or modal approach (again nonlinearity poses problems). Very important check for the launch-phase is Shock Analysis and Random Analysis, both basing again on experimental data depending on the launcher rocket type [1,2,3].

The CBK FE model of PreBOX assembly was tested for sensitivity of response to the mesh type and density (TETRA and HEXA meshes were created, for both linear and quadratic elements). The five models covered a range from 50 000 dof to ca 5 000 000 dof.

RESULTS

The design and structural analyses of PreBOX performed entirely by CBK [4] passed requirements and ESA verification. However, the design will be cross-checked by other partners (electronics, systems) and some modifications are not excluded. It should be also remembered, that after successful analysis and acceptance, the components undergo a whole set of experimental verification in the lab (loads, shakers etc.) – verifying the analysis assumptions and FE models. The components sometimes undergo also destructive testing, to ensure they will survive intact both the lift-off stage and a years-long journey to Jupiter.

REFERENCES

1. D. Steinberg, *Vibration Analysis for electronic Equipment* (John Wiley, NY, 2000).
2. P. Wirsching, T. Paez (Author), K. Ortiz , *Random Vibrations: Theory and Practice* (Dover, 2006).
3. D. N. Herting, *MSC.NASTRAN Advanced Dynamic Analysis* (MSC Corporation, LA, 1997).
4. RPWI - JUICE PREBOX Structural Analysis Report, JUI-RPWI-CBK-PRE-RP-025 (CBK PAN, June 2018)